

## Continuous Duty, Type II, Unsealed Intermittent Duty, Type III, Unsealed

### General Specifications:

- Designed to MIL-R-6106
  - Type II Unsealed Continuous Duty
  - Type III Unsealed Intermittent Duty
  - Covered/Gasketed Contact Area
  - Twin-break Silver Alloy Contacts
- Meets Explosion, Humidity, Salt, Spray, Sand and Dust requirements.
- Altitude: 50,000 feet
- Shock: 25 g's ½ Sine 6 to 9 milliseconds
  - Maximum contact opening: 2 milliseconds
- Acceleration: 10 g's
- Vibration Limits:
  - 5 to 10 Hz: 0.8 in DA
  - 10 to 55 Hz: 0.6 in DA
  - 55 to 2000 Hz: 2 g's
- Temperature Range: -55°C to 71°C
- Insulation Resistance:
  - 100 megohm minimum initially
  - 50 megohm minimum after tests
- Dielectric:
  - 1250 Vac minimum initially
  - 1000 Vac minimum after tests
- Life:
  - Electrical Operations: 50,000 cycles
  - Mechanical Operations at 25% of rated resistive load: 100,000 cycles
- Minimum Current: 10% of rated Dc resistive load
- Intermittent Duty Ratings:
  - % of rated resistive
  - Time on in minutes
  - Cooling time is required between successive overload applications

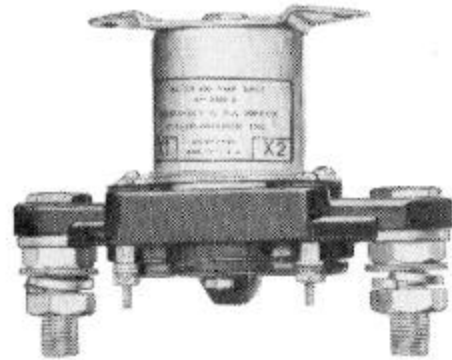

6041H217

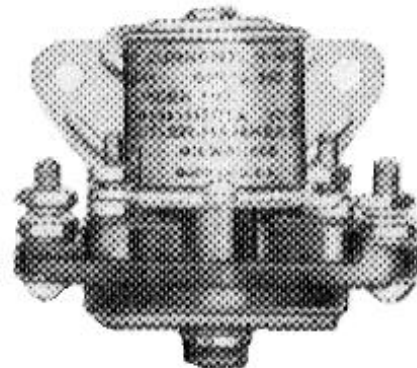

6041H201

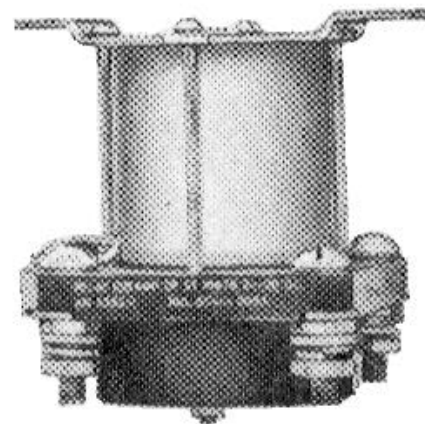

6041H209

### Intermittent Duty Ratings

Minutes			
15	5	1	Inrush
130%	150%	200%	600%

Rupture Time Per MIL-R-6106

(Coil Voltage must be maintained at rated value)

# Power Relays - Unsealed

# EATON

Part Number	Mil-Spec Number	Continuous Pwr. Contacts, Ratings						Contact Operate			Poles and Throw 4/	Weight lbs/gm	Coil Data					Mntg.	Coil V Nom.
		28 Vdc			115/200 V 400 Hz			Milliseconds, Max					Circuit Dia / Dim Fig	Res Ohms +/- 10%	Volts Pick Up 5/	Volts Drop Out	Duty Cyc		
		Res	Ind	Motor	Res	Ind	Motor	OP Time	Rel Time	Cont. Bounce									
9565H2	MS24192-D1	25	25	25	25	25	25				3PST	1.1/498	10/11	54	18	1.5/7	CONT.	BASE	28
9565H29	-	25	25	25	25	25	25				3PST	1.1/498	10/11	1130	70	10/40	CONT.	BASE	120
9565H95	-	25	25	25	25	25	25				3PDT	2.25/1018	16/12	60	18	1.5/7	CONT.	BASE	28
6041H53 2/	-	50	50	50	25	-	-	20	15	5	1PDT	0.54/244	3/3	17	9.5	0.5/3	CONT.	TOP	12
6041H220 2/	MS24187-D1	50	50	50	25	-	-	20	15	5	1PDT	0.54/244	4/3	94	18	1.5/7	CONT.	TOP	28
6041H230	MS24187-D2	50	50	50	25	-	-	20	15	5	1PDT	0.54/244	4/3	56	18	1.5/9	CONT.	TOP	28
6046H39 2/	-	50	50	50	-	-	-				1PDT	2.9/1312	6/7	26	18	1.5/7	CONT.	TOP	28
6041H201	MS24166-D2	50	50	50	-	-	-				1PST	0.6/272	1/4	80	18	1.5/7	CONT.	SIDE	28
6041H149	-	50	50	50	-	-	-				1PST	0.6/272	1/4	60	9	0.5/3	CONT.	SIDE	12
6041H200	MS24166-D1	50	50	50	-	-	-				1PST	0.6/272	1/1	80	16	1.5/7	CONT.	TOP	28
9565H94	MS24193-D1	50	50	50	50	50	50				3PST	1.6/724	10/11	62	18	1.5/7	CONT.	BASE	28
6041H219	MS24178-D1	55	40	40	55	35	-				2PST	.75/399	2/3	56	18	1.5/7	CONT.	TOP	28
6041H80	-	100	80	80	-	-	-				1PST	1.4/634	1/4	73	18	1.5/7	CONT.	SIDE	28
6041H144	-	100	80	80	-	-	-				1PST	1.4/634	1/4	73	18	1.5/7	CONT.	SIDE	28
6041H11	-	100	80	80	-	-	-				1PST	1.4/634	1/3	73	18	1.5/7	CONT.	TOP	28
6041H209	AN3362-1	100	80	80	100	65	-	35	10	3.5	2PST	1.5/679	2/3	43	20	1.5/7	1/	TOP	28
6046H53	MS25031-D1B	100	80	80	75	65	-	20	15	2.5	2PDT	3.5/1584	9/7	47	18	1.5/7	CONT.	TOP	28
9565H13	-	100	75	75	100	75	-				3PST	2.5/1131	12/11	53	18	1.5/7	CONT.	BASE	28
6041H202	MS24171-D2	200	100	100	-	-	-				1PST	1.25/566	1/5	47	18	1.5/7	CONT.	SIDE	28
6041H105	-	200	100	200	-	-	-				1PST	1.25/566	1/5	25	9	.5/3.5	CONT.	SIDE	12
6041H123	-	200	100	200	-	-	-	40	15	5	1PST	1.25/566	1/6	66	18	1.5/7	CONT.	SIDE	28
6041H203	MS24172-D2	200	100	200	-	-	-	25	18	5	1PST	1.25/566	1/5	10	7.5	.5/3	INTER 3/	SIDE	28
6041H212	-	200	100	200	-	-	-				1PST	1.25/555	1/5	66	18	1.5/7	CONT.	SIDE	28
6041H215	MS24171-D1	200	100	200	-	-	-				1PST	1.33/602	1/1	47	18	1.5/7	CONT.	TOP	28
6041H216	MS24172-D1	200	100	200	-	-	-	10			1PST	1.33/602	1/1	6	7.5	.5/3	INTER 3/	TOP	28
6046H46	MS25032-D1	200	100	150	150	100	-				2PDT	5.5/2489	8/7	35	18	1.5/7	CONT.	TOP	28
6041H205	MS24185-D2	400	100	400	-	-	-	60	15	5	1PST	2.6/1176	1/5	60	18	1.5/7	CONT.	SIDE	28
6041H217	MS24185-D1	400	100	400	-	-	-	60	15	5	1PST	2.6/1176	1/1	60	18	1.5/7	CONT.	TOP	28
6041H218	MS24179-D1	400	100	400	-	-	-	20	15	5	1PST	2.6/1176	1/1	10	7	.5/3	INTER 3/	TOP	28
6041H206	MS24179-D2	400	100	400	-	-	-	20	15	5	1PST	2.6/1176	1/5	10	7	.5/3	INTER 3/	SIDE	28

1/ Coil will exceed 95°C temperature rise when left on continuously in 25° ambient, but will not be damaged. At maximum ambient temperature of 71°C, the duty cycle should be limited to 15 minutes "on" time per half hour to obtain maximum coil life.

2/ Continuous and intermittent duty ratings shown are for N.O. pole. N.C. pole rated at ½ the listed continuous DC duty ratings. N.C. pole on 6041H53 and H220 limited to 15 g's shock.

3/ Time on 1 ½ minutes at 29 Vdc. Minimum time off is 3 minutes.

4/ All continuous duty resistive and motor load ratings and all intermittent duty ratings for all 3 pole relays listed under 28 Vdc apply for 120 Vdc systems with all 3 poles of the relay connected in the series.

5/ Pick-up voltage below values shown may cause relay to rapidly cycle on and off (chatter).

6/ Relay must drop-out at voltage value or less and may drop-out at any voltage below the higher voltage noted.

### Typical Wiring Diagrams

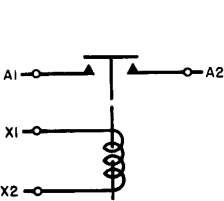

Dia. No. 1

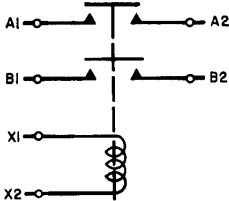

Dia. No. 2

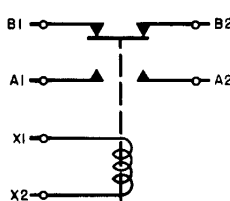

Dia. No. 3

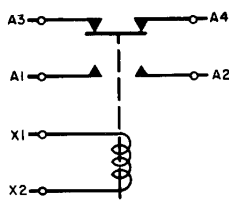

Dia. No. 4

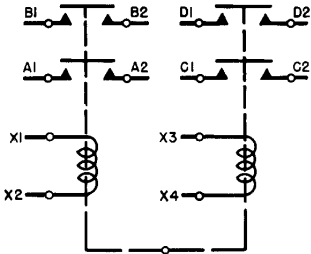

Dia. No. 8

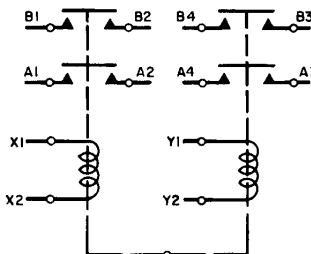

Dia. No. 9

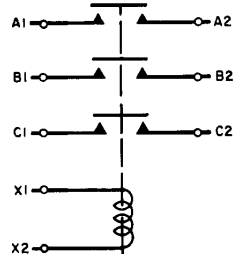

Dia. No. 10

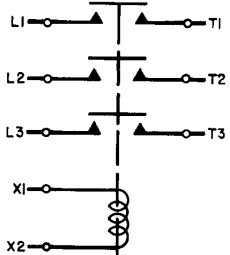

Dia. No. 12

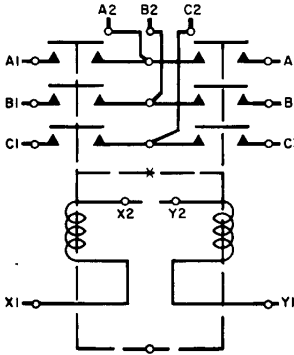

Dia. No. 16

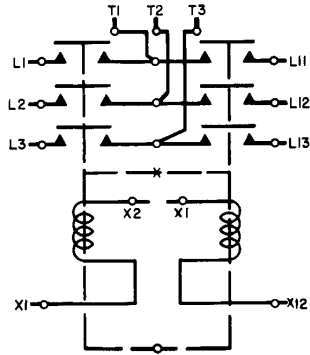

Dia. No. 18